

## TECHNICAL DATA

<b>Maximum Delivery:</b>	26.5 Litres/min	<b>Accessories Included:</b>	Exhaust Air Silencer
<b>Max. Working Pressure:</b>	6.9 Bar (100 psi)	<b>Shipping Weight:</b>	1.4 Kg (3.0 Lb) - Poly. 2.0 Kg (4.5 Lb) - Kynar.
<b>Max. Solid Particle Size:</b>	1.5 mm (1/16")	<b>Shipping Dimensions:</b>	160 mm x 230 mm x 120 mm
<b>Air Inlet:</b>	1/4" BSP(F)	<b>Fluid Inlet/Outlet:</b>	3/8" BSP(F)
<b>Suction Lift (Dry):</b>	3.05 M (10')	<b>Temperature Limits:</b>	<b>Polypropylene :</b> Minimum 0°C (32°F) Maximum 79°C (175°F)
<b>Suction Lift (Wet):</b>	6 M (20')		<b>Kynar :</b> Minimum -12°C (10°F) Maximum 107°C (225°F)
		<b>dB(A) Rating</b>	78 dB(A)

FLUID CONNECTIONS	CAPACITY	MAX SOLIDS	MAX DISCHARGE HEAD	DISPLACEMENT /STROKE
3/8" BSP (F)	0 - 26.5 Liters/Minute (0 - 5.8 Gallons/Minute)	1.5 mm (1/16")	70 Meters (230 ft)	0.034 Litres (0.007 Gallons U.K.)

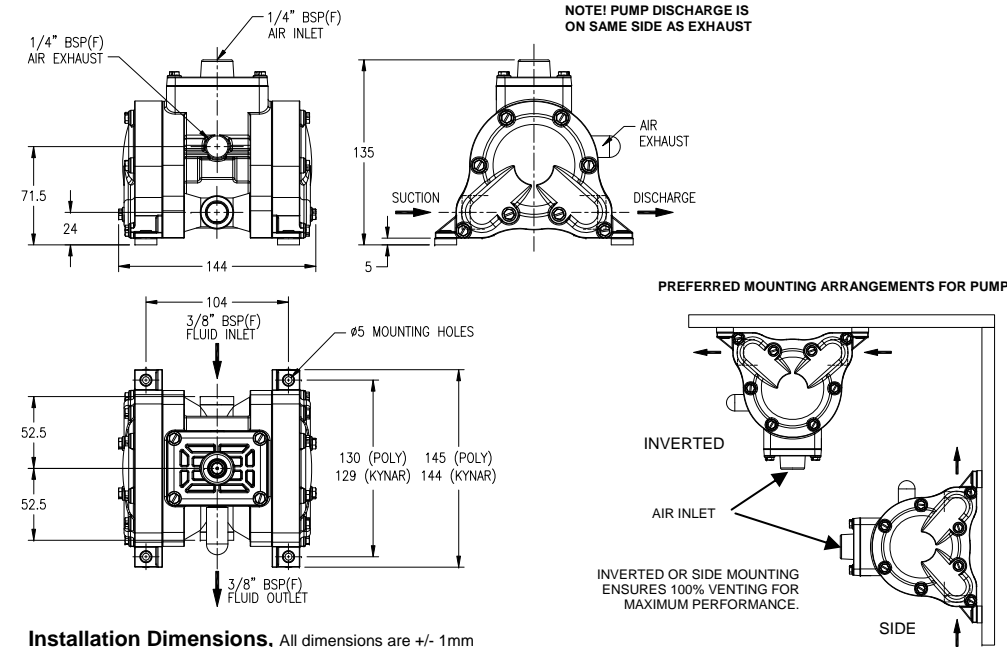

**Installation Dimensions**, All dimensions are +/- 1mm



**BLAGDON PUMP**

A Unit of IDEX Corporation

LAMBERT ROAD, ARMSTRONG, WASHINGTON,  
TYNE & WEAR NE37 1QP, ENGLAND.  
TEL.: 0044 (0) 191 4177475  
FAX.: 0044 (0) 191 4175435  
Web Site: www.blagdonpump.com  
E-Mail: sales@blagdonpump.com

HG-CF-1106 Rev. G 18.02.09



# B10

## AIR OPERATED DOUBLE DIAPHRAGM PUMP OWNERS OPERATING & SAFETY MANUAL



### PRINCIPLE OF PUMP OPERATION

This spring loaded check valve pump is powered by compressed air and is a 1:1 ratio design. The inner side of one diaphragm chamber is alternately pressurised while simultaneously exhausting the other inner chamber. This causes the diaphragms, which are connected by a common rod, to move in a reciprocating action. (As one diaphragm performs a discharge stroke the other diaphragm is pulled to perform the suction stroke in the opposite chamber.) Air pressure is applied over the entire inner surface of the diaphragm while liquid is discharged from the opposite side of the diaphragm. The diaphragm operates in a balanced condition during the discharge stroke which allows the pump to be operated at discharge heads of over 230 feet (70 meters) of water.

For maximum diaphragm life, keep the pump as close to the liquid being pumped as possible. Positive suction head in excess of 10 feet of liquid (3.048 meters) may require a back pressure regulating device to maximize diaphragm life.

Alternate pressurising and exhausting of the diaphragm chamber is performed by an internally mounted, pilot operated, 2 way type distribution valve. When the spool shifts to one end of the centre body, inlet pressure is applied to one chamber and the other diaphragm chamber exhausts. When the spool shifts to the

opposite end of the centre body, the pressure to the chambers is reversed. The chambers are connected with rotatable manifolds with a spring loaded suction and discharge check valve for each chamber, maintaining flow in one direction through the pump.

### INSTALLATION

Your installation will depend on the type of fluid being pumped and your application needs. To reduce the risk of serious bodily injury and damage to property, never use fluids in this pump which are not compatible with the wetted components. Contact your local distributor or the manufacturer for system design assistance & compatibility if necessary.

The pump is fitted with spring loaded check valves, as a result the pump can be mounted in any position to suit the application needs. Ensure the pump is securely mounted to avoid movement and possible risk of bodily injury.

**PRESSURE** The pump delivers the same pressure at the discharge outlet as the air pressure applied at the air inlet.

**NOTE:** A Pressure Regulator should be installed where air supply could exceed 100 psi.

## SAFETY

Your **B10** pump is a high performance unit capable of achieving high outputs at high efficiencies. However, as is common with pneumatic equipment, the pump efficiencies is reliant upon the air being clean, dry and filtered. Failure to comply with these requirements may lead to loss of performance and reduced component life and in extreme cases, permanent damage to the pump.

To avoid leaks, ensure that all fluid connections are tight. The use of PTFE thread tape correctly applied should be used to ensure 100% leakproof connections.

**Failure to ensure 100% sealability of the suction connection could adversely affect suction performance.**

If you are pumping hazardous fluids, or operating the pump in an enclosed area, it is essential that the exhaust from the pump is piped away to a safe location. When pumping hazardous fluids the above instructions must be adhered to in order to ensure safe operating procedures.

*(Under certain operating conditions the failure of internal components can lead to the pumped fluid being exhausted via the pump exhaust outlet).*

## WARNING

**NEVER place your hands over or near the pump suction inlet. Powerful suction could cause serious bodily injury.**

**FLUSH THE PUMP** This pump was tested with clean water. If this solution could contaminate or react with the fluid you are pumping, flush the pump thoroughly with a solvent/detergent to clean internal components. The solvent/detergent must be compatible with the pump materials of construction. Care should be taken to flush the pump each time it is disassembled for maintenance or repair.

**CAUTION** Ensure that only the recommended grade of lubricating oil is used.

BLAGDON PUMPS do not require any dedicated lubrication system, however a periodical application of an SAE 10 lubricating oil will help to prolong seal life. Other grades of oil may cause the Air Logic System to operate intermittently,

thereby causing a loss of output and failure to operate.

If the pump accelerates or is running too fast due to a lack of fluid, then stop it immediately by shutting off the air supply. A dry pump will accelerate to a high speed causing wear to elastomers.

If the fluid you are pumping tends to dry up or set when it is not moving, then flush the pump as often as necessary to prevent the fluid from drying in the pump. Drain the pump thoroughly before storing. If feasible, invert pump to allow any fluid to drain from the non-return valves.



## IMPORTANT!

Read these instructions completely, before installation and start-up. It is the responsibility of the purchaser to retain this manual for reference. Failure to comply with the recommendations stated in this manual will damage the pump, and void factory warranty.



## WARNING!

Before maintenance or repair, shut off the compressed air line, bleed the pressure, and disconnect the air line from the pump. The discharge line may be pressurized and must be bled of its pressure.



## WARNING!

Take action to prevent static sparking. Fire or explosion can result, especially when handling flammable liquids. The pump, piping, valves, containers or other miscellaneous equipment must be grounded.



## IMPORTANT!

This pump is pressurized internally with air pressure during operation. Always make certain that all bolting is in good condition and that all of the correct bolting is reinstalled during assembly.



## WARNING!

When used for toxic or aggressive fluids, the pump should always be flushed clean prior to disassembly.

## Performance Curve

All figures based on pumping clean water at ambient temperature

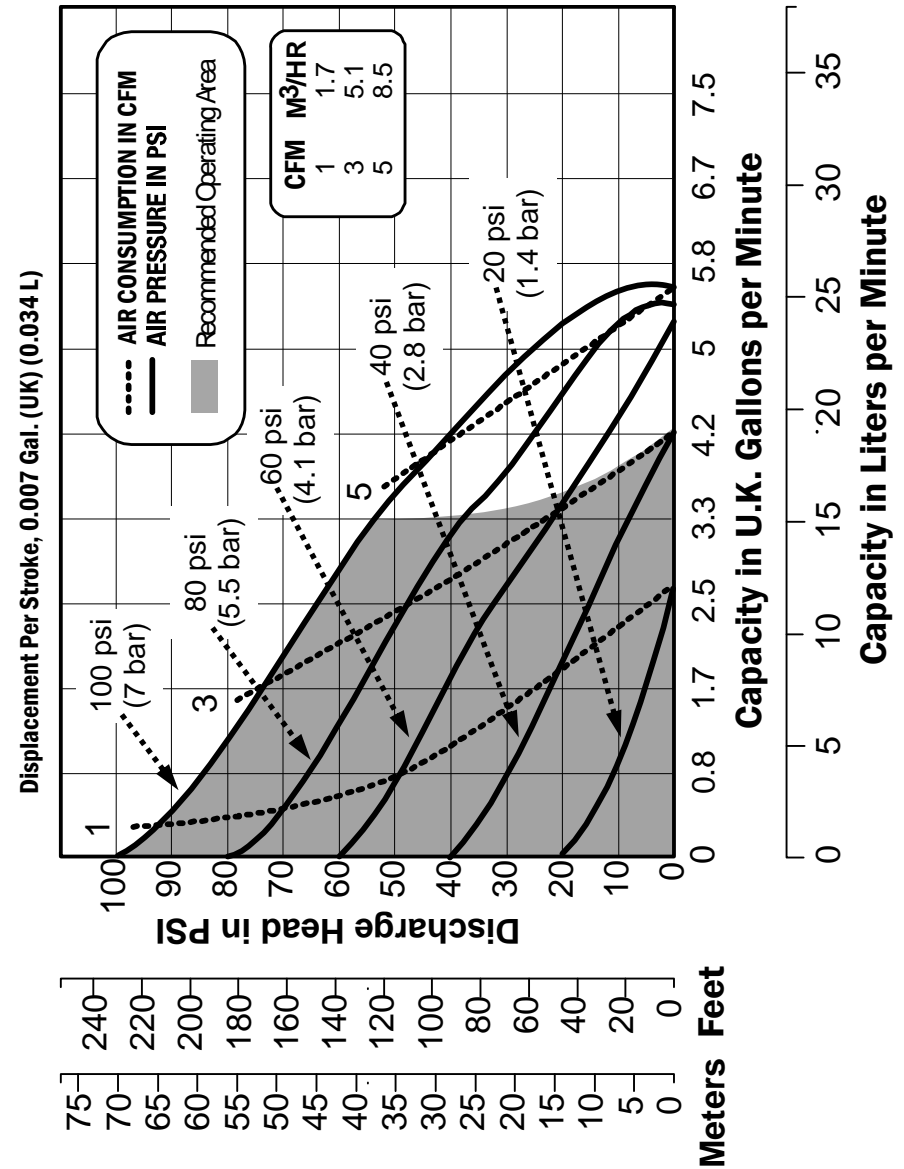

- These items are available as a recommended Air Side Kit, ASK1001P, see page three for details.
- ◆ These items are available as a recommended Wet Side Kit, see page three for Part Nos.

For any further information regarding available kits, please contact your local stockist / distributor.

## Parts List

Item	Description	Qty.	Standard: Polypropylene		
1	Centre Section	1	E801A		
2	Valve Gasket	□	E800J	AIR VALVE ASSEMBLY E800 (items 2 - 10)	
3	Valve Insert	□	E500H		
4	Air Diverter	□	10-075		
5	End Cap	2	E800D		
6	End Cap O-Ring	□	E500E		
7	Valve Screw	4	10-050		
8	Valve Body	1	10-048		
9	Valve Spool	1	E500B		
10	Valve Spool U-Cup	□	P98-104A		
11	Main & Pilot Shaft O-Ring	□	E503B		PILOT VALVE ASSEMBLY
12	Pilot Shaft Spacer	5	E503C		
13	Shaft Retainer	2	E801B		
14	Pilot Shaft	1	E803A		
15	Pilot Shaft Snap Ring	2	E503D		
16	Shaft Retainer Screw	4	E501C		
			<b>POLY / SANTOPRENE PUMPS</b>	<b>KYNAR / PTFE PUMPS</b>	
17	Valve Seat	◆	4	10-022(Poly)	10-039(Kynar)
18	Spring	◆	4	10-030	10-030
19	Valve Stem	◆	4	10-005	10-038
20	Valve Seat Seal	◆	8	10-073 Santoprene Option	10-045 PTFE Option
21	Water Chamber Bolt (Short)		12	10-051	10-051
22	Water Chamber Bolt (Long)		4	10-052	10-052
23	Water Chamber		2	10-002	10-036
24	Foot Pad		4	10-035	10-035
25	Outer Diaphragm Plate		2	10-023(poly)	10-023(poly)
				10-040(kynar)	10-040(kynar)
26	Diaphragm	◆	2	10-032(R)	10-044
27	Inner Diaphragm Plate		2	C126	C126
28	Main Shaft		1	10-028	10-028
29	Manifold		2	10-003	10-037
30	Muffler		1	06-034	06-034



### WARNING!

Before doing any maintenance on the pump, be certain all pressure is completely vented from the pump, suction, discharge, piping, and all other openings and connections. Be certain the air supply is locked out or made non-operational, so that it cannot be started while work is being done on the pump. Be certain that approved eye protection and protective clothing are worn all times in the vicinity of the pump. Failure to follow these recommendations may result in serious injury or death.



### CAUTION!

Before pump operation, inspect all gasketed fasteners for looseness caused by gasket creep. Re-torque loose fasteners to prevent leakage. Follow recommended torques stated in this manual.



### WARNING!

Airborne particles and loud noise hazards. Wear ear and eye protection.



### WARNING!

In the event of diaphragm rupture, pumped material may enter the air end of the pump, and be discharged into the atmosphere. If pumping a product which is hazardous or toxic, the air exhaust must be piped to an appropriate area for safe disposition.



### RECYCLING

Many components of BLAGDON air operated double diaphragm pumps are made of recyclable materials. We encourage pump users to recycle worn out parts and pumps whenever possible, after any hazardous pumped fluids are thoroughly flushed.

### TYPICAL ORDER CODE = B10. 01. P P. R P P

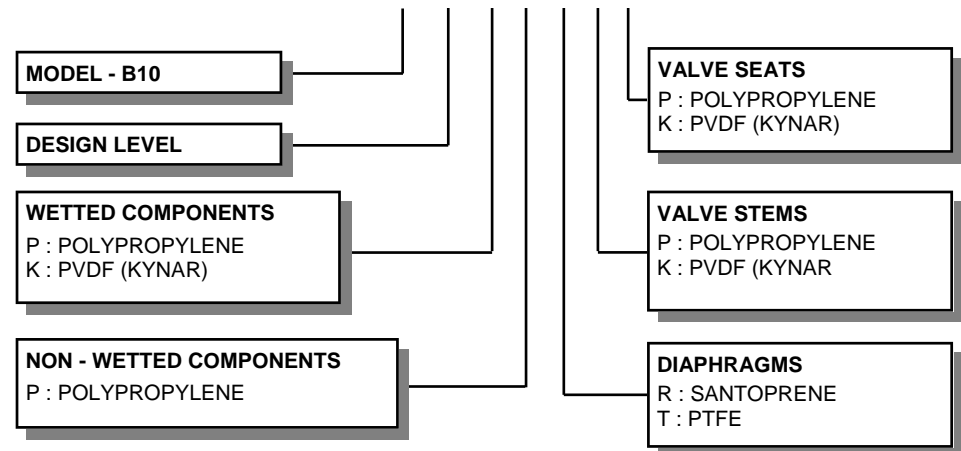

SPARES KITS :- REFER TO TABLE & DRAWING ON PAGES 4,5 & 6

ASK1001P - AIR SIDE KIT			
ITEM	DESCRIPTION	QTY	PART NUMBER
2	VALVE GASKET	1	E800J
3	VALVE INSERT	1	E500H
4	AIR DIVERTER	1	10-075
6	END CAP O-RING	2	E500E
10	VALVE SPOOL U-CUP	2	P98-104A
11	PILOT SHAFT O-RING	6	E503B
11	MAIN SHAFT O-RING	2	E503B

WETTED END KITS	
PART NO.	DESCRIPTION
SA10RPP	POLY./SANTOPRENE
SA10TPP	POLY./PTFE
SA10RKK	KYNAR/SANT.
SA10TKK	KYNAR/PTFE

**Note.** These descriptions refer to the Pump body and Diaphragm materials.

